

Technical Data Sheet:

J150

Market

The J150 is a lightweight, compact rotary vane compressor designed for the oil free discharge of bulk liquids from general purpose tankers, e.g. liquid foodstuff, solvents, acids, alkalis, hot bitumen, resins and other chemicals.

The main benefit of using a compressor to discharge liquid is that the product does not come into contact with the machine. This eliminates the problems of compatibility between the liquid and the compressor components.

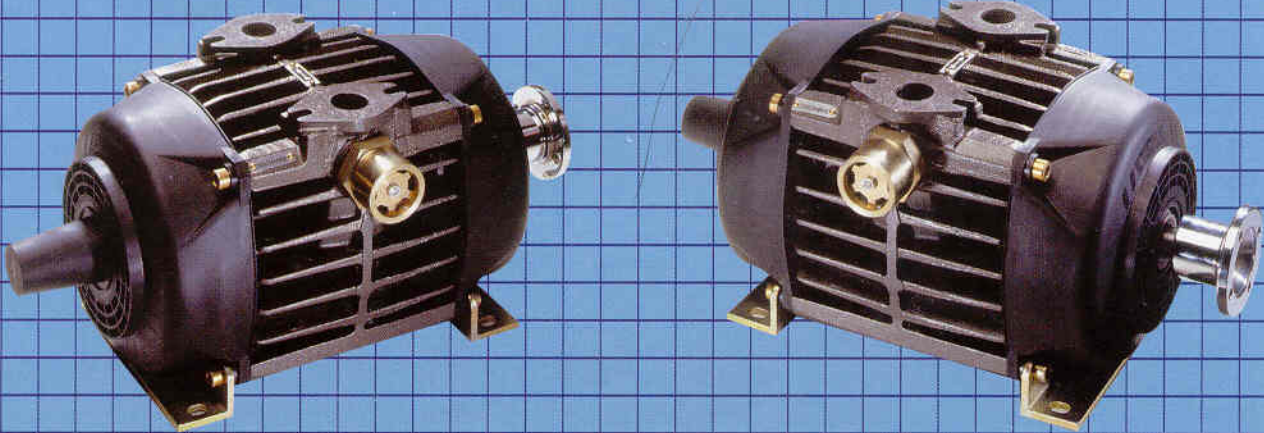

Specification

General design

The machine is oil free sliding vane design supported by bearing arrangements at both ends of the rotor.

All the components used in the main bore cavity are coated aluminium or stainless steel to minimise any possibility of atmospheric corrosion.

Mounting

The compact size and shape of the compressor make it ideal for simple mounting inside the chassis on most vehicles to enable low cost direct PTO driving.

The through shaft allows CW or ACW input drive rotation and the compressor can be installed in 3 orientations to provide the maximum mounting flexibility.

The Standard Package

The standard packaging consists of the following equipment:

- Basic J150 machine and mounting kit
- Induction kit including inlet filter
- Relief valve
- Check valve

Dimensions

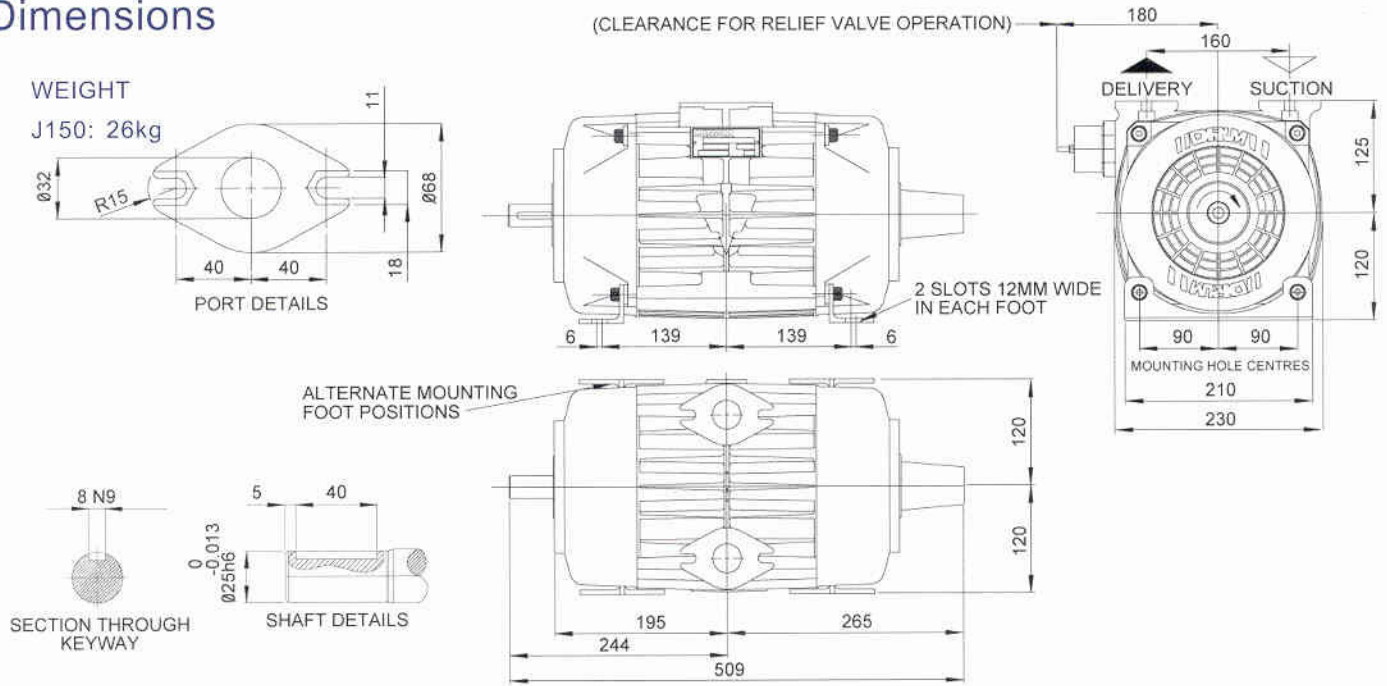

Optional ancillaries

- Inlet silencer
- Delivery filter
- Various flange packs as required
- Various drive flanges

Drive options

- Prop. shaft drive: Direct from a vehicle PTO
- Hydraulic drive: Several drives can be offered depending on the application
- Electric motor drive: Packages on base frames
- Engine drive: Packages on base frames

Performance

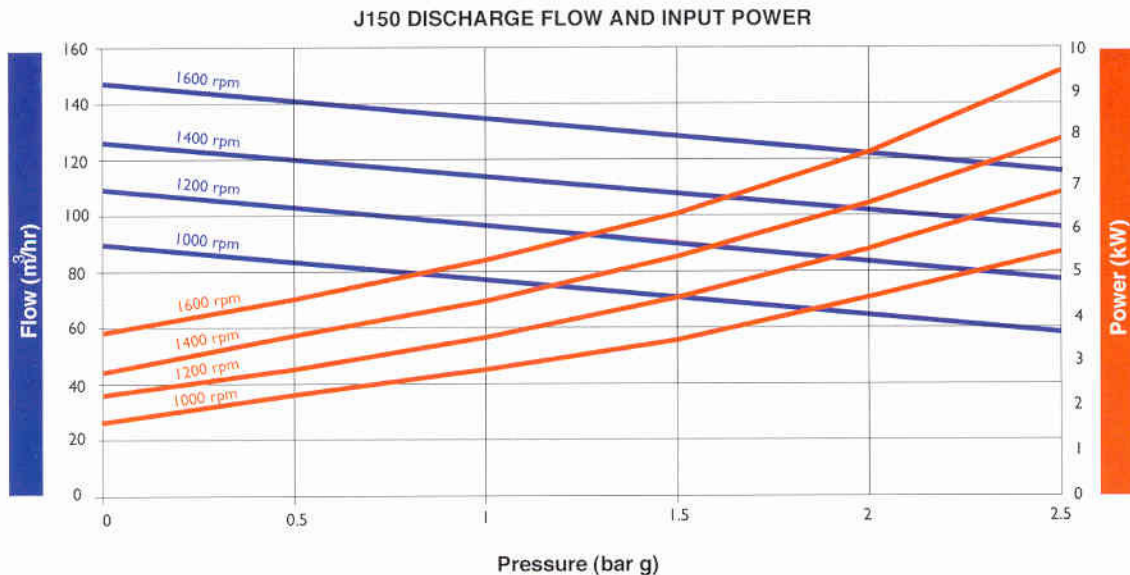

Discharge flow measured in accordance with BS1042/ISO 5167-1/BS ISO TR 15377 and referred to standard ambient conditions (1013 mbar, 20°C)



Kutnohorská 369
109 00 Praha 10

tel.: +420 274 024 225
fax: +420 274 024 226
email: info@alfimex.cz
web: www.alfimex.cz